

# AV-N29220<sub>R</sub> / AV-N29220<sub>S</sub>

## STANDARD CIRCUIT DIAGRAM

### ■ NOTE ON USING CIRCUIT DIAGRAMS

#### 1.SAFETY

The components identified by the  $\Delta$  symbol and shading are critical for safety. For continued safety replace safety critical components only with manufactures recommended parts.

#### 2.SPECIFIED VOLTAGE AND WAVEFORM VALUES

The voltage and waveform values have been measured under the following conditions.

- (1)Input signal : Color bar signal
- (2)Setting positions of each knob/button and variable resistor :Original setting position when shipped
- (3)Internal resistance of tester :DC 20k  $\Omega$ /V
- (4)Oscilloscope sweeping time :H  $\Rightarrow$  20 $\mu$ S/div  
:V  $\Rightarrow$  5mS/div  
:Others  $\Rightarrow$  Sweeping time is specified
- (5)Voltage values :All DC voltage values
- \* Since the voltage values of signal circuit vary to some extent according to adjustments, use them as reference values.

#### 3.INDICATION OF PARTS SYMBOL [EXAMPLE]

- In the PW board :R1209 $\rightarrow$ R209

#### 4.INDICATIONS ON THE CIRCUIT DIAGRAM

##### (1)Resistors

###### ●Resistance value

- No unit :[ $\Omega$ ]  
K :[K  $\Omega$ ]  
M :[M  $\Omega$ ]

###### ●Rated allowable power

- No indication :1/16 [W]  
Others :As specified

###### ●Type

- No indication :Carbon resistor  
OMR :Oxide metal film resistor  
MFR :Metal film resistor  
MPR :Metal plate resistor  
UNFR :Uninflammable resistor  
FR :Fusible resistor

\*Composition resistor 1/2 [W] is specified as 1/2S or Comp.

##### (2)Capacitors

###### ●Capacitance value

- 1 or higher :[pF]  
less than 1 :[ $\mu$ F]

###### ●Withstand voltage

- No indication :DC50[V]  
Others :DC withstand voltage [V]  
AC indicated :AC withstand voltage [V]

\*Electrolytic Capacitors

47/50[Example]:Capacitance value [ $\mu$ F]/withstand voltage[V]

- Type
- No indication :Ceramic capacitor  
MY :Mylar capacitor  
MM :Metalized mylar capacitor  
PP :Polypropylene capacitor  
MPP :Metalized polypropylene capacitor  
MF :Metalized film capacitor  
TF :Thin film capacitor  
BP :Bipolar electrolytic capacitor  
TAN :Tantalum capacitor

##### (3)Coils

- No unit :[ $\mu$ H]  
Others :As specified

##### (4)Power Supply

- \_\_\_\_\_ :B1 :B2(12V)  
 :9V :5V

\*Respective voltage values are indicated

##### (5)Test point

- :Test point :Only test point display

##### (6)Connecting method

- :Connector :Wrapping or soldering  
 :Receptacle

##### (7)Ground symbol

- :LIVE side ground  
 :ISOLATED(NEUTRAL) side ground  
 :EARTH ground  
 :DIGITAL ground

### 5.NOTE FOR REPAIRING SERVICE

This model's power circuit is partly different in the GND. The difference of the GND is shown by the LIVE : ( $\perp$ ) side GND and the ISOLATED(NEUTRAL) : ( $\neq$ ) side GND. Therefore, care must be taken for the following points.

- (1)Do not touch the LIVE side GND or the LIVE side GND and the ISOLATED(NEUTRAL) side GND simultaneously. If the above caution is not respected, an electric shock may be caused. Therefore, make sure that the power cord is surely removed from the receptacle when, for example, the chassis is pulled out.
- (2)Do not short between the LIVE side GND and ISOLATED(NEUTRAL) side GND or never measure with a measuring apparatus ( oscilloscope, etc.) the LIVE side GND and ISOLATED(NEUTRAL) side GND at the same time. If the above precaution is not respected , a fuse or any parts will be broken.

◇ Since the circuit diagram is a standard one, the circuit and circuit constants may be subject to change for improvement without any notice.

##### ◇ NOTE

Due improvement in performance, some part numbers show in the circuit diagram may not agree with those indicated in the part list.

When ordering parts, please use the numbers that appear in the Parts List.

# CONTENTS

**SEMICONDUCTOR SHAPES** ..... 2-2

**BLOCK DIAGRAM** ..... 2-3

**CIRCUIT DIAGRAMS**

**MAIN PWB CIRCUIT DIAGRAM** ..... 2-5

**MAIN PWB, CRT SOCKET PWB CIRCUIT DIAGRAMS** ..... 2-7

**PATTERN DIAGRAMS**

**MAIN PWB, CRT SOCKET PWB PATTERN** ..... 2-9

**CHANNEL CHART** ..... 2-11

## SEMICONDUCTOR SHAPES

### TRANSISTOR

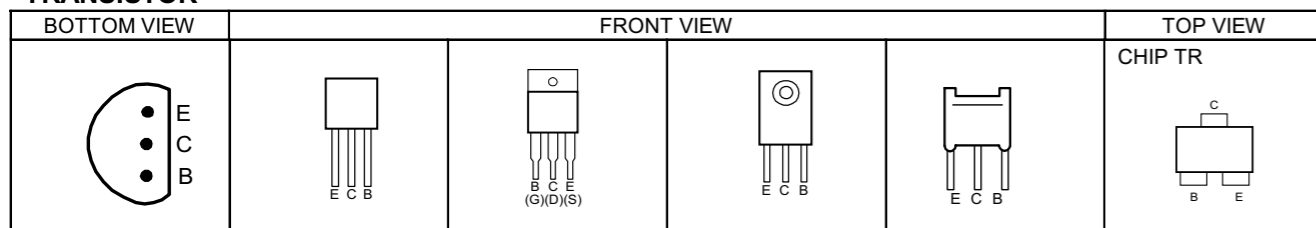

### IC

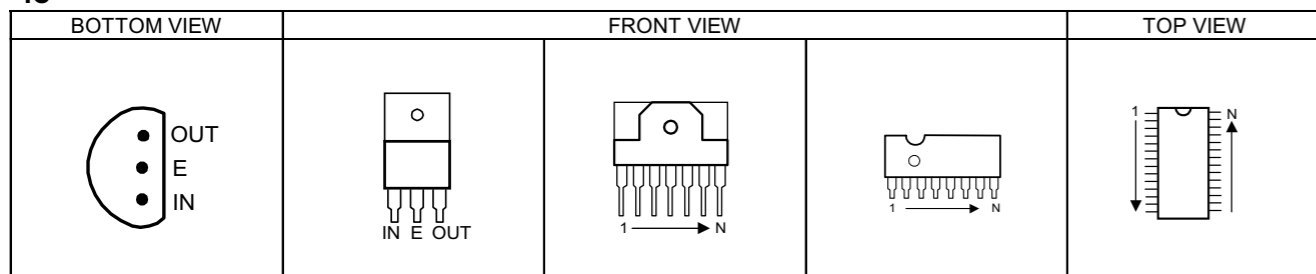

### CHIP IC

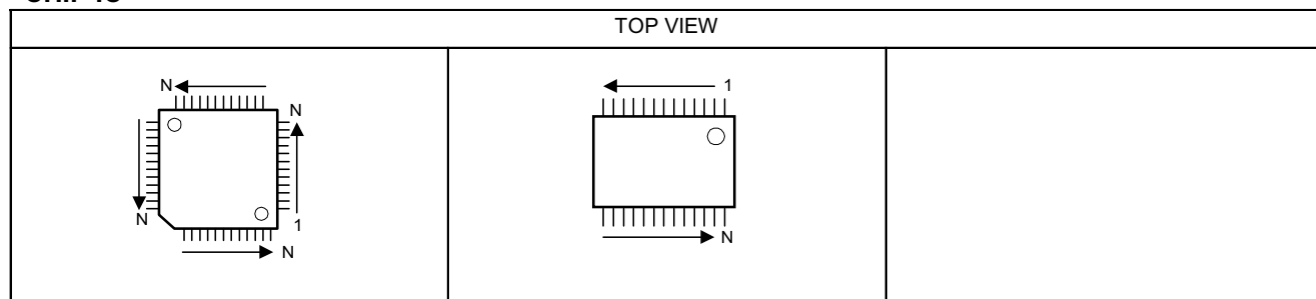

## CHANNEL CHART

| MODE |      | BAND    | CHANNEL | TUNER |    |    |
|------|------|---------|---------|-------|----|----|
| TV   | CATV |         | DISP.   | BAND  |    |    |
| ○    | ○    | VL      | 02      | I     |    |    |
|      |      |         | 03      |       |    |    |
|      |      |         | 04      |       |    |    |
|      |      |         | 05      |       |    |    |
|      |      |         | 06      |       |    |    |
|      |      |         | 07      |       |    |    |
|      |      | VH      | 08      | II    |    |    |
|      |      |         | 09      |       |    |    |
|      |      |         | 10      |       |    |    |
|      |      |         | 11      |       |    |    |
|      |      |         | 12      |       |    |    |
|      |      |         | 13      |       |    |    |
|      |      |         | 14      |       |    |    |
| x    | ○    | MID     | 15      | I     |    |    |
|      |      |         | 16      |       |    |    |
|      |      | SUPER   | 17      | II    |    |    |
|      |      |         | 18      |       |    |    |
|      |      |         | 19      |       |    |    |
|      |      |         | 20      |       |    |    |
|      |      |         | 21      |       |    |    |
|      |      |         | 22      |       |    |    |
|      |      |         | HYPER   |       | 23 | IV |
|      |      |         |         |       | 24 |    |
|      |      |         |         |       | 25 |    |
|      |      |         |         |       | 26 |    |
|      |      | 27      |         |       |    |    |
|      |      | 28      |         |       |    |    |
|      |      | 29      |         |       |    |    |
|      |      | 30      |         |       |    |    |
|      |      | 31      |         |       |    |    |
|      |      | 32      |         |       |    |    |
|      |      | ULTRA   | ○       | ULTRA | 33 | IV |
|      |      |         |         |       | 34 |    |
|      |      |         |         |       | 35 |    |
|      |      |         |         |       | 36 |    |
| 37   |      |         |         |       |    |    |
| 38   |      |         |         |       |    |    |
| 39   |      |         |         |       |    |    |
| 40   |      |         |         |       |    |    |
| 41   |      |         |         |       |    |    |
| 42   |      |         |         |       |    |    |
| 43   |      |         |         |       |    |    |
| 44   |      |         |         |       |    |    |
| 45   |      |         |         |       |    |    |
| 46   |      |         |         |       |    |    |
| 47   |      |         |         |       |    |    |
| ○    | x    | SUB MID | 48      | I     |    |    |
|      |      |         | 49      |       |    |    |
|      |      |         | 50      |       |    |    |
|      |      |         | 51      |       |    |    |
|      |      |         | 52      |       |    |    |
|      |      |         | 53      |       |    |    |
|      |      |         | 54      |       |    |    |
|      |      |         | 55      |       |    |    |
| ○    | x    | UHF     | 56      | IV    |    |    |
|      |      |         | 57      |       |    |    |
|      |      |         | 58      |       |    |    |
|      |      |         | 59      |       |    |    |
|      |      |         | 60      |       |    |    |
|      |      |         | 61      |       |    |    |
|      |      |         | 62      |       |    |    |
|      |      |         | 63      |       |    |    |
|      |      |         | 64      |       |    |    |
|      |      |         | 65      |       |    |    |
| 66   |      |         |         |       |    |    |
| 67   |      |         |         |       |    |    |
| 68   |      |         |         |       |    |    |
| 69   |      |         |         |       |    |    |
| 70   |      |         |         |       |    |    |

| MODE  |      | BAND  | CHANNEL     | TUNER |
|---|------|-------|-------------|-------|
| TV  | CATV |       | DISP.       | BAND  |
| x   | ○    | ULTRA | 71          | IV    |
|   |      |       | 72          |       |
|   |      |       | 73          |       |
|   |      |       | 74          |       |
|   |      |       | 75          |       |
|   |      |       | 76          |       |
|   |      |       | 77          |       |
|   |      |       | 78          |       |
|   |      |       | 79          |       |
|   |      |       | 80          |       |
|   |      |       | 81          |       |
|   |      |       | 82          |       |
|   |      |       | 83          |       |
|   |      |       | 84          |       |
|   |      |       | 85          |       |
|   |      |       | 86          |       |
|   |      |       | 87          |       |
|   |      |       | 88          |       |
|   |      |       | 89          |       |
|   |      |       | 90          |       |
|   |      |       | 91          |       |
|   |      |       | 92          |       |
|   |      |       | 93          |       |
|   |      |       | 94          |       |
|   |      |       | 100         |       |
| 101   |      |       |             |       |
| 102   |      |       |             |       |
| 103   |      |       |             |       |
| 104   |      |       |             |       |
| 105   |      |       |             |       |
| 106   |      |       |             |       |
| 107   |      |       |             |       |
| 108   |      |       |             |       |
| 109   |      |       |             |       |
| 110   |      |       |             |       |
| 111   |      |       |             |       |
| 112   |      |       |             |       |
| 113   |      |       |             |       |
| 114   |      |       |             |       |
| 115   |      |       |             |       |
| 116   |      |       |             |       |
| 117   |      |       |             |       |
| 118   |      |       |             |       |
| 119   |      |       |             |       |
| 120   |      |       |             |       |
| 121   |      |       |             |       |
| 122   |      |       |             |       |
| 123   |      |       |             |       |
| 124   |      |       |             |       |
| 125   |      |       |             |       |
| ○   | x    | UHF   | 01          | I     |
|   |      |       | 96          |       |
|   |      |       | 97          |       |
|   |      |       | 98          |       |
|   |      |       | 99          |       |
| ○   | x    | UHF   | 14          | IV    |
|   |      |       | ?           |       |
|   |      |       | TOTAL 180CH |       |
|   |      |       | { VHF 124CH |       |
|   |      |       | { UHF 56CH  |       |
| <p>NOTE:<br/>TO RECEIVE THE SUBSCRIPTION OR PREMIUM PROGRAMMING FROM CERTAIN CABLE COMPANIES. SPECIAL ADAPTERS MAY BE REQUIRED.</p> |      |       |             |       |

# BLOCK DIAGRAM

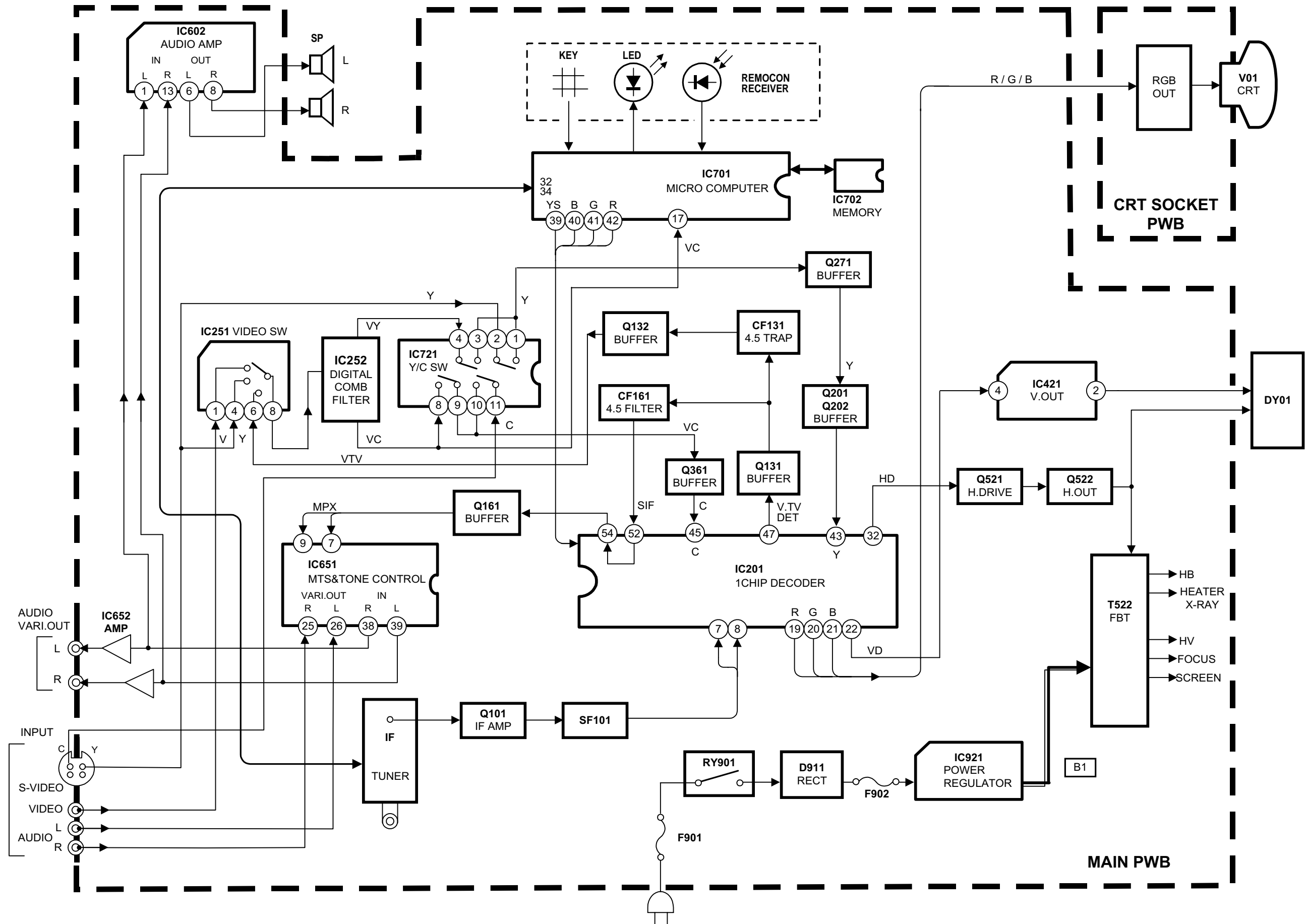

CIRCUIT DIAGRAMS MAIN PWB CIRCUIT DIAGRAM

MAIN PWB  
SFV-1071A-M2 (AV-N29220/R)  
SFV-1074A-M2 (AV-N29220/S)

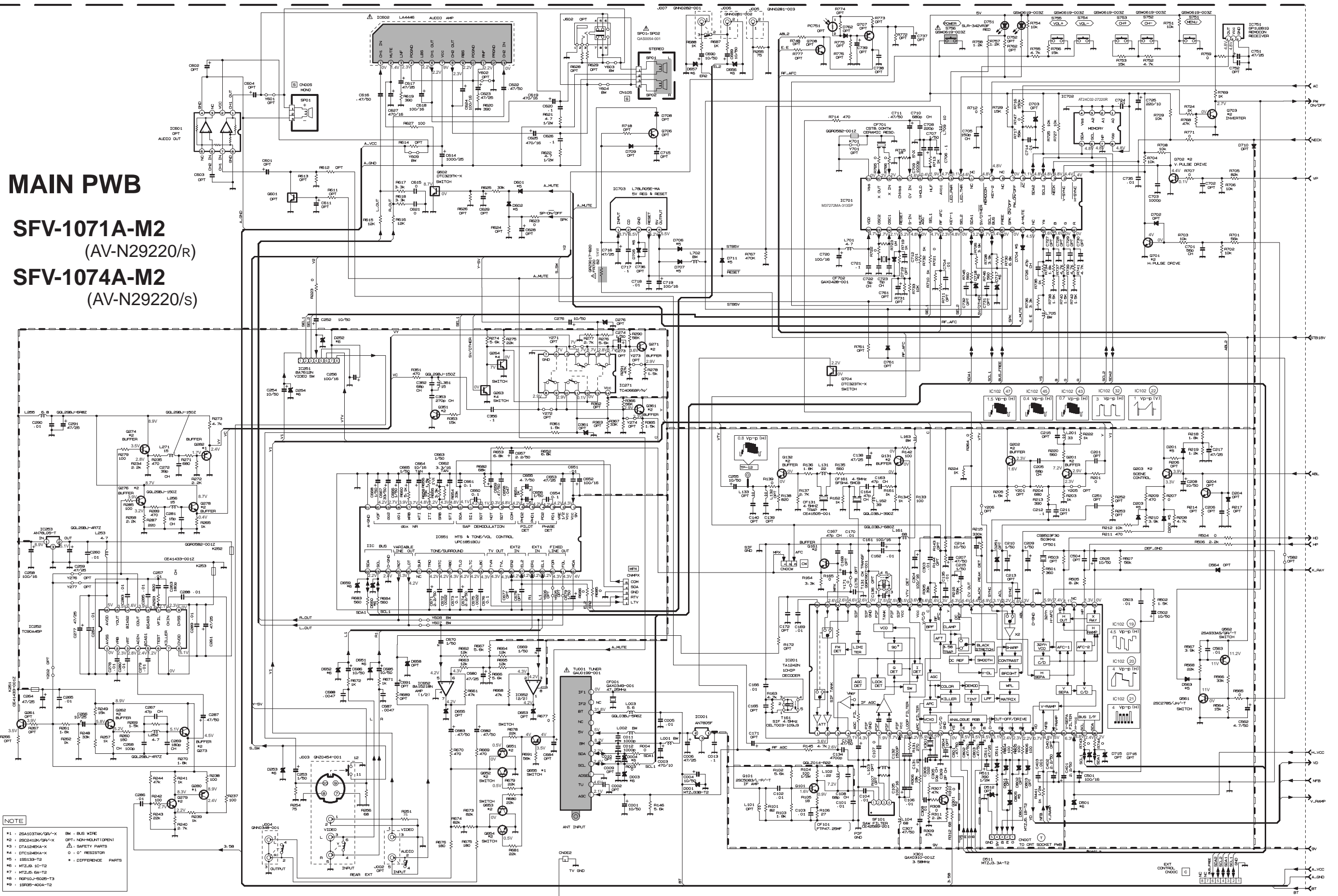

NOTE  
#1 : 2S1437AK/GR-V-X    BW : BUS WIRE  
#2 : 2S143412K/GR-V-X    OPT : NON-MOUNT (OPEN)  
#3 : DT12124KA-X    Δ : SAFETY PARTS  
#4 : DT12124KA-X    ○ : RESISTOR  
#5 : 1S1131-T2    \* : DIFFERENCE PARTS  
#6 : MT2120-1C-T2  
#7 : MT2125-6A-T2  
#8 : RP101J-5020-T3  
#9 : 1S1335-400A-T2

MAIN PWB, CRT SOCKET PWB CIRCUIT DIAGRAM

# MAIN PWB

## SFV-1071A-M2

(AV-N29220/R)

## SFV-1074A-M2

(VA-N29220/S)

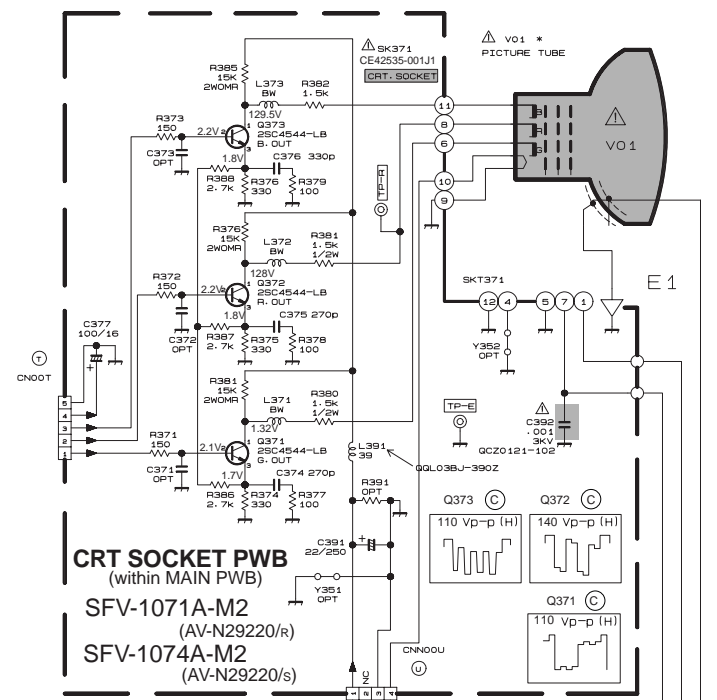
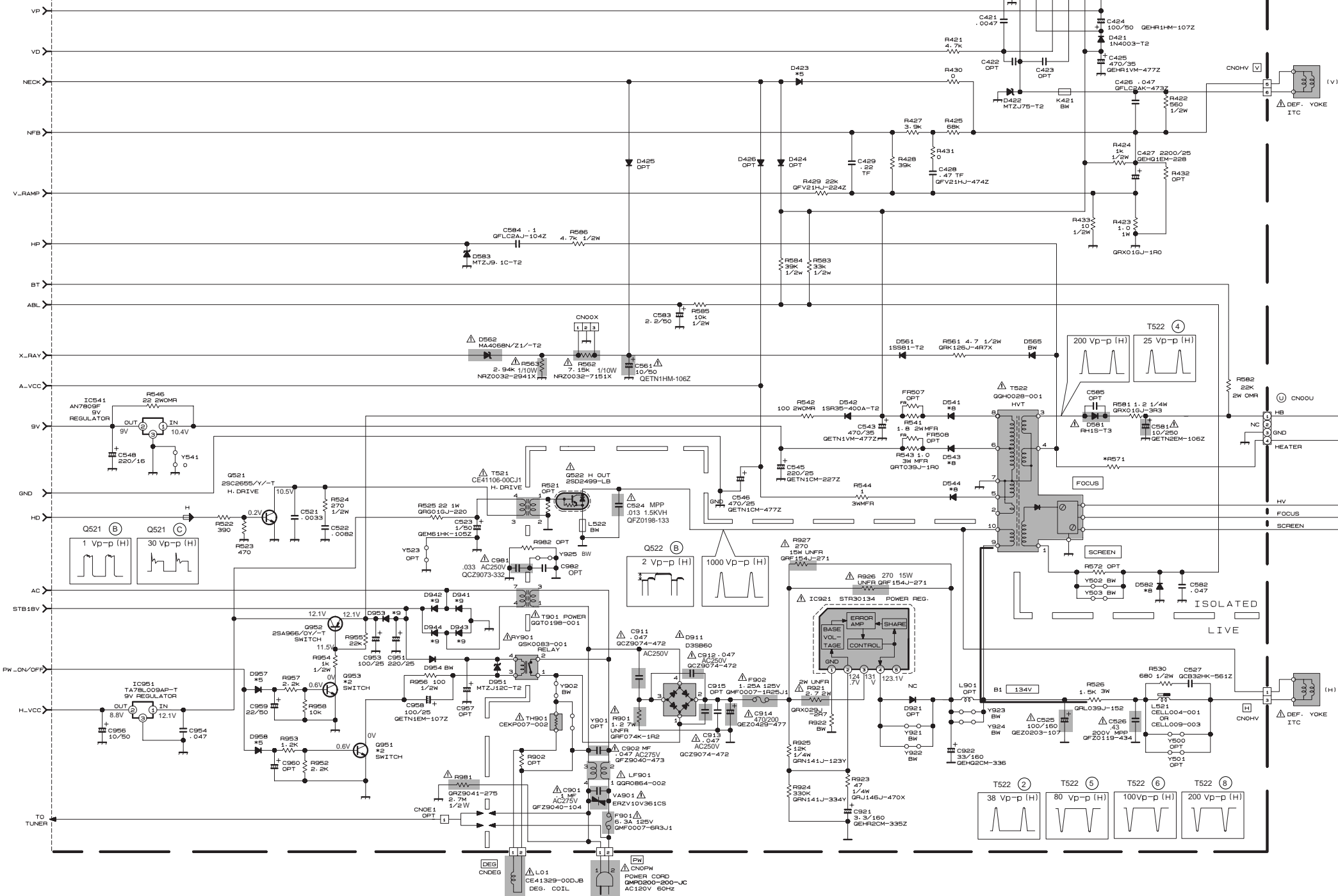

PATTERN DIAGRAMS MAIN PWB, CRT SOCKET PWB PATTERN

